

PERFECT TIMING: AN EAST COAST TAKTFAHRPLAN?

Rail consultancy Passenger Transport Networks was commissioned by Atoc to look into whether Dutch and Swiss timetabling principles could be applied to the East Coast Main Line to create an improved timetable. Jonathan Tyler explains

A railway's timetable is the fundamental feature of its product, or 'offer'. That fact has not been sufficiently acknowledged in Britain and the national timetable remains unco-ordinated, however good individual services may be. This weakness is longstanding, but it has been exacerbated by the objectives and procedures under which the railway is presently managed and regulated. This article argues that circumstances on the East Coast Main Line (ECML) should prompt a reappraisal.

Until now, the approach has been pragmatic. Where paths could be woven through a decidedly non-regular timetable, access rights have been granted either to the incumbent franchisee or to an open-access operator, on the basis respectively of franchise commitments or of evidence about unmet demand for through-services and the supposed benefits of competition. The process has not been without controversy, notably over the initial paths for Hull Trains and the later argument about rights for Grand Central, and franchisees have understandably bridled at the consequences of the uneasy coexistence of franchising and open access. Nevertheless, the scheme has worked well enough. Now, though, it is in turmoil.

The aggregate number of paths sought by the franchisee, two open access operators and the freight companies far exceeds what can be physically accommodated. This represents the very mother of a prioritisation problem – with inadequate precedents, no recognised economic model to guide decisions and the risk of controversial compromise. Moreover, although the advantages of repeating-interval timetables are almost universally accepted, the discipline they introduce may compound the problem in subtle ways. It is, therefore, helpful to look at the

issues from the other direction. What happens if the essential core service is planned first and definitively? Is a change in the economic and social climate occurring in which securing an environmentally-sustainable modal split makes a more coherent timetable more of a priority?

In Switzerland, the Taktfahrplan is an integrated national timetable produced by statutorily-specified consensus building, involving democratic bodies, the national railway, numerous smaller railways and the operators of buses, boats and mountain lines. It was revised in 2004, and the plan for 2030 is being prepared. Freight trains compete for an allocation of dedicated paths within each hourly cycle, especially on the crucial mountain traverses. In The Netherlands in 2006 the infrastructure company, the state-owned passenger business and freight companies jointly commissioned a timetable that would deliver benefits to all three parties while realising national expectations in respect of connectivity. The outcome was then approved by the government.

In both countries, open access for passenger trains is nominally possible, but it is rendered barely relevant by the comprehensive efficacy of the overall plan and by the practical absence of spare capacity. Clearly this approach, which has not been challenged under European law, is incompatible with the institutions and policies that have developed since the Railways Act 1993. But it does not follow that Britain has nothing to learn from these, and similar, examples, bearing in mind, too, that per-capita use of the railway in these countries exceeds use in Britain and that both timetable transformations reaped considerable gains in traffic.

Is it possible that the Swiss and Dutch



York station: Connection times would be much improved if Swiss ideas were implemented on the ECML.

principles and methodology could shape a timetable for the ECML that is superior – in terms of connectivity, deployment of capacity, net benefits and the public interest – to any that might emerge from an edifice of dispersed responsibilities? And if so, is there a way in which open access could be incorporated? In 2006 Atoc commissioned Passenger Transport Networks (PTN) to research these questions, using the Swiss Viriato software.

The three key features of a Taktfahrplan are:

- A coherent network of services – proper attention is paid to the spacing and linking of trains so that potential customers are offered travel opportunities from any A to any B at appropriate intervals and without lengthy waits;
- Hourly cycles that repeat without significant variation throughout the day; and
- Mirror-image timings to ensure consistency between the plans for each direction.

Optimal spacing of services contrasts with the common case of separate operators' standard-hours not meshing sensibly. Similarly, the network is so organised that the more important a node is as an interchange point, the more trains, ideally, coincide there in order to



www.railimages.co.uk

● Cross-country and trans-Pennine services should complement ICEC services and maximise frequencies for non-London place-pairs north of Doncaster.

The ICEC service pattern specified by the Department for Transport rests on similar conclusions, but its conformance to Takt principles may have been prejudiced by other objectives such as target journey times and 'memorable' departure-minutes. Moreover, in a sequential design process, the services of other companies either present operational constraints or are ignored: they cannot be treated as important complements.

The other major, but not always recognised, factor is the sharing of tracks with the London suburban service. The outer-suburban group comprises the Cambridge non-stops, the 'semi-fasts' – alternately serving Cambridge and Peterborough – and the 'slows' alternating likewise. The six trains in each hour are tightly arranged in an admirable pattern, whereby each half-hour is identical south of Hitchin; their relationship with the Welwyn inner-suburban service will improve when that steps up from three to four trains per hour.

Combining the desirable ICEC and suburban cycles leads to a scheme in which the Edinburgh and the slower Leeds trains run close together and the faster Leeds and the Newcastle likewise in the other half-hour. All four stop at Peterborough, which also secures an enhanced service for Stevenage. The two pairs of paths are identical south of Doncaster, while the fifth train follows one pair and precedes the next into London (southbound) or Doncaster (northbound). This arrangement creates well-ordered half-hourly cycles through the Welwyn constriction. It is theoretically possible to graph

minimise connection times. Implementation of these principles is naturally conditioned by the market and operational characteristics of each route. Since these concepts differ markedly from contemporary British practice, the exercise could only be meaningful if a clean-sheet strategy were adopted. Should the benefits be proven to be substantial, the proposed plan could then be treated as the long-term objective, with interim adjustments made where necessary.

For the Inter-City East Coast (ICEC) and related services, our demand studies are summarised in the table (right). Four firm conclusions were drawn:

- The pattern of two Newcastle (at least alternately extended from and to Scotland) and two Leeds services in each standard hour has emerged from cumulative adjustment over many years and is highly determined;
- The time-differential (if stops are not identical) and spacing of each pair of trains should be such as to maintain an effective half-hourly service;
- The passenger-kilometres that Retford, Newark and Grantham generate do not compare with the big northern flows – hence, as total demand grows, the stronger the case for serving them with separate trains and accelerating longer-distance services;

Is it possible that the Swiss and Dutch methodology could shape a timetable for the ECML that is superior in terms of connectivity, deployment of capacity and net benefits?

six passenger trains and one 120km per hour freight every hour over the critical Doncaster to Peterborough section.

However, achieving acceptable performance is likely to result in less-than-ideal passenger paths. Furthermore, the growth expectations of the freight businesses require more than one path per hour – a frequency that would prevent a sensible configuration of the passenger service.

This inescapably means diverting all daytime freight to the route via Lincoln. Not to start the necessary upgrade urgently will not only undermine the optimal core passenger service for the east coast, but will also complicate the assimilation of open access services. Logically, the sixth path should be taken in alternate hours by Hull Trains and a Lincoln service. In order to complete the pattern, Hull Trains would gain rights to serve Newark and Peterborough. This would remove an anomaly without adding to the London journey-time, because a clean timetable eliminates excessive margins.

In a timetable constructed from first principles, it may be feasible to overlay extra peak services on the basic service, rather than rearrange it. Here, two extra paths for the franchisee give the desired total of eight per hour. By definition, and without freight, the seventh and eighth paths exist off-peak,

Inter-City East Coast : demand, specification and proposed <i>Taktfahrplan</i> structure										
	Demand status	Inter-change status	Specification for London services per standard hour		First half-hour			Second half-hour		
			Through train	Connection	EDNB	LEDS B	'fifth'	LEDS A	NCLT	HULL/LNCL
Edinburgh Wvly	****	****	✓	✓	✓					
Berwick-u-T	*		✓	(✓)	✓					
Newcastle uT	****	***	✓	✓	✓					
Durham	**		✓	✓					✓	
Darlington	***	**	✓	✓	✓				✓	
Northallerton	*		✓	(✓)					✓	
York	****	***	✓	✓	✓		✓		✓	
Leeds	****	***	✓	✓		✓		✓		
Wakefield	***		✓	✓		✓		✓		
Doncaster	***	**	✓	✓		✓			✓	HT / -
Retford	*		✓	(✓)			✓			HT / -
Newark NG	**	*	✓	✓			✓			✓
Grantham	**	*	✓	✓			✓			✓
Peterborough	***	***	✓	✓	✓		✓		✓	✓
Stevenage	** [IC]	*				✓			✓	
London KX					✓	✓	✓	✓	✓	✓
A similar analysis covered non-London flows			✓ essential (✓) desirable		This shows the southbound sequence. Under the mirror-image rule the sequence would be reversed northbound.					

although it might be unwise from a performance viewpoint to use both in every hour. Yet even one would enable Grand Central to develop its ideas. Although the proposals have not yet been operationally validated, we have been scrupulous in respecting the rules of the plan or explicit about our reasons for deviating slightly from them. The timetable could be introduced with limited alterations to the poorly-configured infrastructure, although it would work better with certain improvements – and note that planning in the Swiss manner itself influences priorities in investment programmes.

Evaluations using Moira, the industry-standard tool for comparing timetables, indicate gross revenues exceeding those from other draft timetables, probably sufficiently to offset a small increase in resources. A wider social evaluation would undoubtedly extend the advantage. Gains would come particularly from enhanced non-London offers and from eliminating poor connections with associated services at Edinburgh, Newcastle, York, Doncaster, Newark, Grantham and Peterborough. The systematic approach has shown how these could be enhanced through regularisation and mainland-European standards of briskness. Over time, provided that everyday management of interchange is good, one might expect a corresponding uplift in business.

In order to benefit from adopting the ‘zero-minute’ principle – a de facto European standard that focuses interchanges at the principal nodes on the hour and half-hour – and to deliver efficient stock diagrams for the franchise operator, some traditional timing practices would be abandoned, in particular ‘round-number’ minutes at selected departure points.

In consequence, while the suburban service would remain structurally unchanged, its timings would be moved around the clock, with knock-on effects on diagrams to be negotiated. Both open access operators are required to participate in planning a standard-hour ECML timetable. Any new plan may upset existing diagrams, and yet the needs of a relatively small business cannot reasonably have a disproportionate influence on the best scheme for the whole route. In the Taktfahrplan, turnarounds that would be manageable in a unitary railway are necessarily lengthened if train-sets cannot be inter-worked.

Judging the balance of sub-optimal diagrams against the rewards of competition and new through-services will not be easy. PTN is confident that it has identified the best practicable solution to the capacity conundrum.

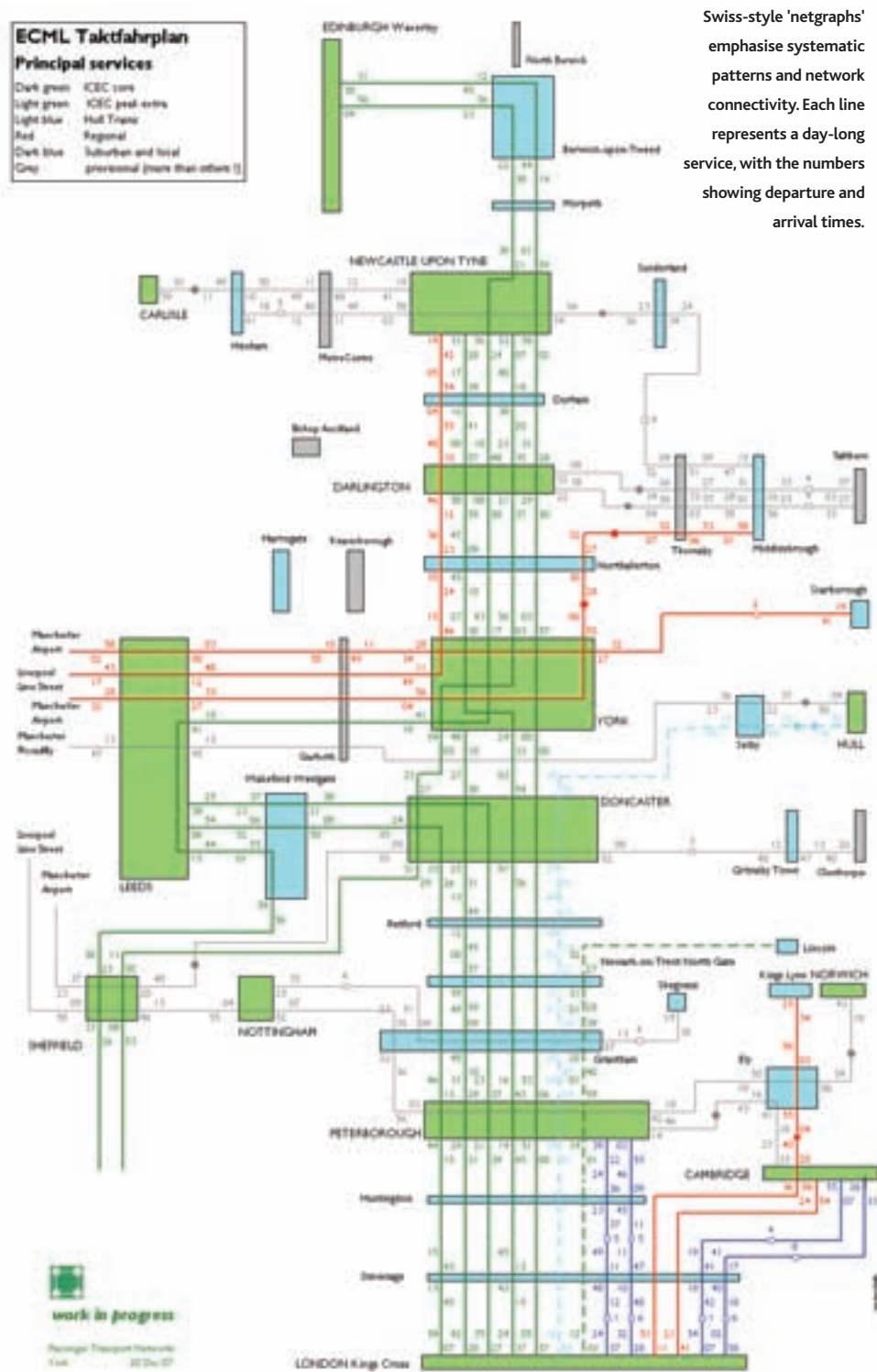

Swiss-style ‘netgraphs’ emphasise systematic patterns and network connectivity. Each line represents a day-long service, with the numbers showing departure and arrival times.

It is superior to any piecemeal methodology, while enabling the franchisee to meet its objectives, satisfying the principal open access aspirations and fulfilling the statutory obligations to promote use of the railway, including multi-operator journeys.

A final thought. Suppose the ECML case for Taktfahrplan is made, then the case for the extension of centralised but consensual planning of integrated timetables across the national network would probably follow. That

could become the dramatic, unifying and popular vision for the nation’s passenger railway that has so far failed to materialise.

Jonathan Tyler joined British Railways as a Traffic Apprentice in 1962. His York-based consultancy, Passenger Transport Networks, specialises in transport policy and timetabling strategy. Copies of the netgraph (above) are available on request. Contact: ptn@btconnect.com.